

BOSSARD

Proven Productivity

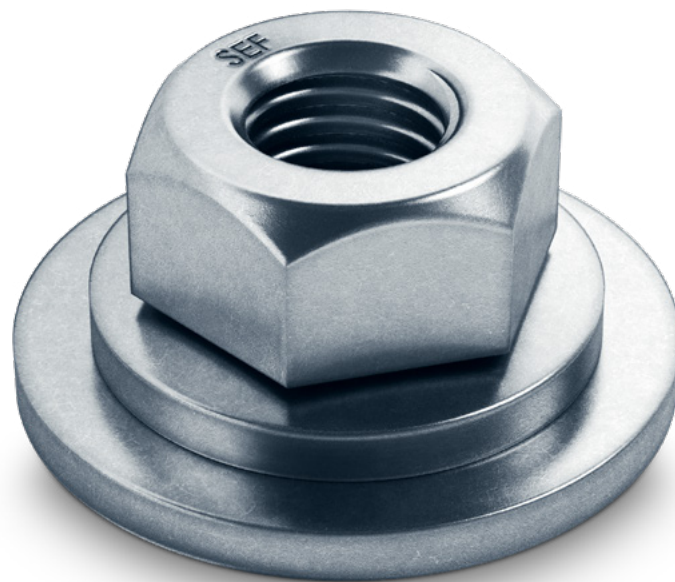

ecosyn[®]-SEF

Operationally safe contact screw connection



«ecosyn[®]-SEF stands for
Safe Electromechanical
Fastener.»

ECOSYN®-SEF

Operationally safe contact screw connection

ecosyn®-SEF combines a self-locking nut with an integrated conical spring washer and large contact surface.

One fastening element, many advantages

ecosyn®-SEF is a multifunctional fastening element for the safe connection of electrically conductive contacts, especially in the high-voltage range. But ecosyn®-SEF is also excellently suited for purely mechanical connections. The combination of several functions in a single component offers many advantages:

- Rationalisation in procurement and logistics
- Shorter preparation and installation times
- Reduction of assembly errors
- Increased process reliability for automated processing
- Increasing the security of the connection
- Reusability of the element

Requirements for high voltage cable connectors

Operationally safe electrical devices set reliable contact screwings ahead. Increasing specifications such as EU directives (RoHS, REACH, etc.) and relevant design specifications are increasing the requirements for current-carrying parts. With short clamping conditions with varying material pairings, separation points and different operating temperatures, the spring assembly can counteract a loss of preload. The integrated spring washer should intentionally not be pressed flat so that it is not subject to any thermal expansion due to electrical heating. The resistance is sufficient to Clamping force to approx. 75-90% of the nominal assembly to maintain the pretensioning force. With vibrations applied

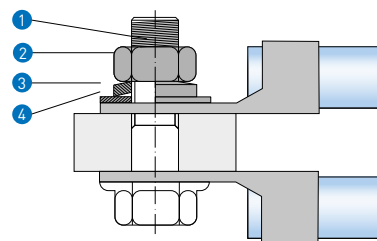

Thread lock with single elements

All in one

- 1 Thread lock
 - 2 Nut
 - 3 Conical spring washer*
 - 4 Washer
- } ecosyn®-SEF

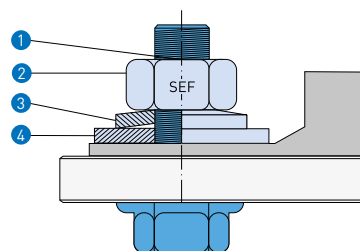

Four functional elements in one = ecosyn®-SEF

or external loads on the clamping point, the special thread Spirallock® has proven itself against loosening of the contact screw connections. The washer reduces surface indentations due to the repeat assembly, which ensures a perfect electrical current transmission. The larger contact surface of the ecosyn®-SEF reduces the surface pressure and can be effective for long holes bridge the power transmission.

*The use of screw connections with spring elements is recommended by the relevant standards for electrical connections.

Self-locking thread technology

Spiralock® Corporation has redesigned the standard female thread form and added a special 30 degree wedge ramp at the root of the male thread. This special female thread form, called Spirallock®, fits all screws with standard metric threads. The advantages for ecosyn®-SEF:

- Extremely resistant to vibrations
- No other safety mechanisms required
- Compatible with standard male thread parts
- Problem-free reusability
- Improved connection lifetime
- Temperature resistant up to 300 °C depending on the version
- Chemical resistance

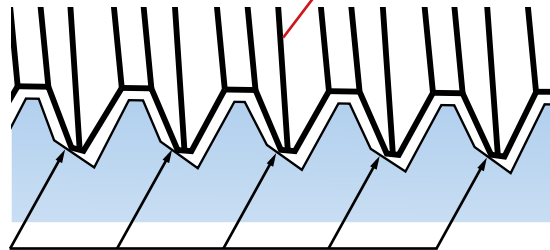
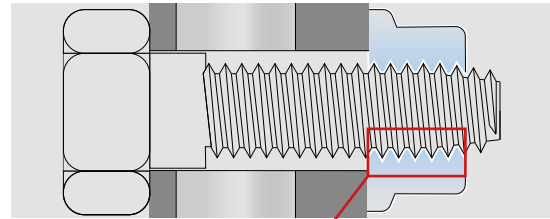

Wedge ramps Spirallock® in female thread

Testing of vibration resistance according to DIN 65151

Two plates braced together with a screw are subjected to a forced vibration (relative movement). Unsecured screw connections loosen within a short time completely. ecosyn®-SEF resists the dynamic transverse stresses that are screwed parts are effective. It maintains up to 80% of the original assembly preload force.

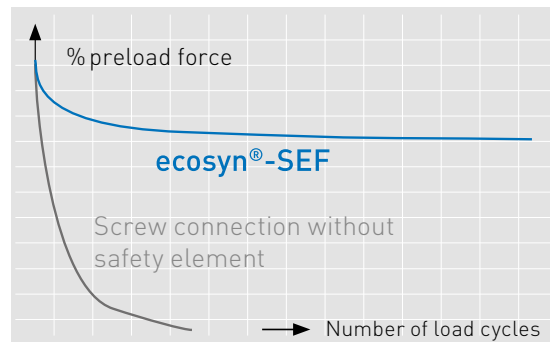

Loss of preload force in vibration test

Tightening torques ecosyn®-SEF

Tightening torque M_A [Nm] and achievable pretensioning forces F_M [kN] for ecosyn®-SEF nuts with 90% utilization of the yield point $R_{p0.2}$

Nut	Screw material	Friction coefficient $\sim\mu_{tot}$	Standard values Tightening torque M_A [Nm]		
			M6	M8	M10
BN 33855 Class 8	Steel 8.8	0,12 to 0,24	12	28	55
		\sim Preload force F_M [kN] ¹⁾	10	19	29

¹⁾ Guide values with bare fasteners for achievable prestressing F_M [kN]

All recommendations should always be checked by practical installation tests.

Tightening torque and contact resistance

The electrical conductivity, also known as conductivity or EC value indicates how distinct the ability of a substance is to conduct an electric current.

The contact resistance is the electrical resistance that is generated at the point of contact when components are connected. This depends on the material used and on the quality of the connection. In order to keep the contact resistance low and to pre-

vent heat generation, the pretensionings should be set at $\geq 75\%$ of Rp0.2 (0.2% proof stress in N/mm²) of the corresponding bolt strength up to approx. 90% Rp0.2. The materials used and their operating conditions with heat generation must be taken into account for the design. Relevant regulations may deviate from the above procedure and must then be specifically checked and, if necessary, adapted.

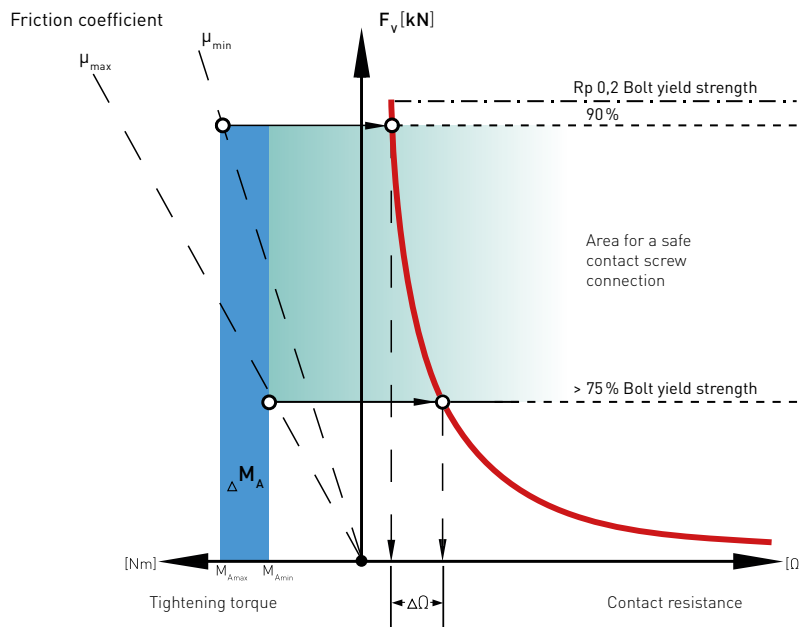

Influencing variables for safe contact screw connections

With electrical contacts, the function of the desired energy transfer depends on the electrical contact resistance of the connection. This is decisively influenced by the clamping force, material pairing and contact surface design with the surface condition. A suitable material pairing reduces the risk of contact corrosion.

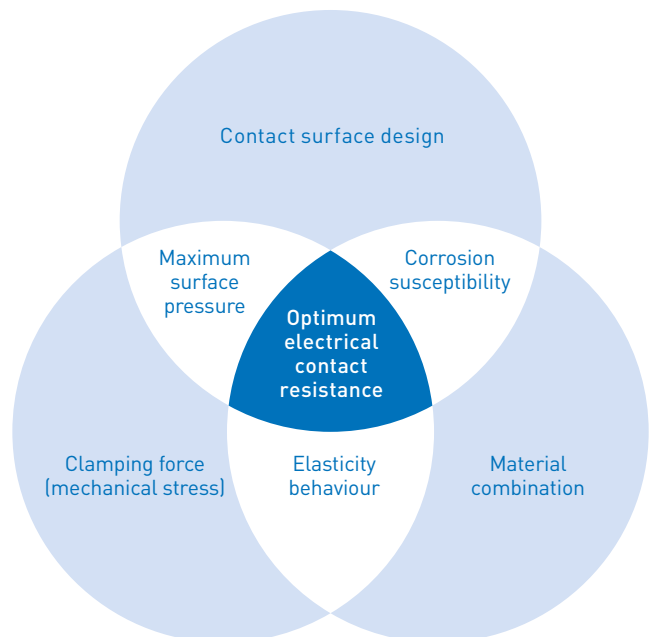

Product range locknut with conical spring washer

BN 33855

Steel strength class 8

ZnNi/Zinc flake coating, added lubricant

d ₁ (mm)	M6	M8	M10
e min.	11,05	14,38	18,9
s nom.	10	13	17*
m max.	5,3	6,8	8,4
a nom.	2,3	2,4	2,7
d ₂ max.	18	24	30
h ~	9,1	11,7	14,2

*Width across flats (M10) according to DIN934

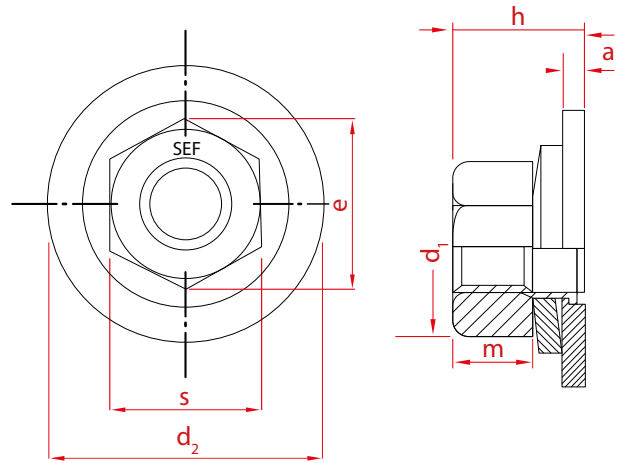

Fields of application

ecosyn®-SEF nuts are particularly suitable for electrical contacts, slotted screw connections and connections subject to vibration:

- Electric mobility
- Rail vehicles (e.g. power electronics)
- Electrical devices with safety-relevant connections
- High voltage batteries
- Transformers
- slotted connections, e.g. for adjustments
- Compounding of non-ferrous metals with large coefficients of expansion with temperature fluctuations
- Screw connections of components made of aluminium, copper or soft materials with high settlement

Product features

- Design of the contact glands for high-voltage and low-voltage applications
- Proven Spirallock® loosening protection
- High compensating capacity against settling phenomena
- Multifunctional solution for efficient assembly
- Large area coverage for large through holes



Please consult your local Bossard E-Shop for the current range and dimensions. Other types on request.

PROVEN PRODUCTIVITY – A PROMISE TO OUR CUSTOMERS

The strategy for success

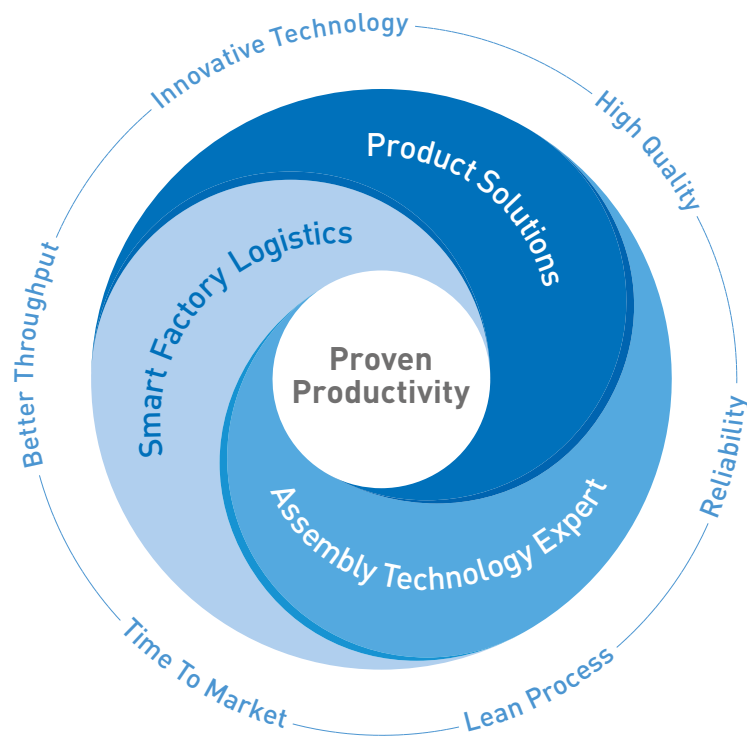

From years of cooperation with our customers we know what achieves proven and sustainable impact. We have identified what it takes to strengthen the competitiveness of our customers. Therefore we support our customers in three strategic core areas.

Firstly, when finding optimal **Product Solutions**, that is in the evaluation and use of the best fastening part for the particular function intended in our customers' products.

Second, our **Assembly Technology Expert** services deliver the smartest solutions for all possible fastening challenges. Our services cover from the moment our customers developing a new product, to

assembly process optimization as well as fastening technology education for our customers' employees.

And thirdly, optimising our clients' productions in a smart and lean way with **Smart Factory Logistics**, our methodology, with intelligent logistics systems and tailor-made solutions.

Understood as a promise to our customers, "Proven Productivity" contains two elements: Firstly, that it demonstrably works. And secondly, that it sustainably and measurably improves the productivity and competitiveness of our customers.

And this for us is a philosophy which motivates us every day to always be one step ahead.

www.bossard.com