

Data sheet - DRS 110x2

High-precision locknuts

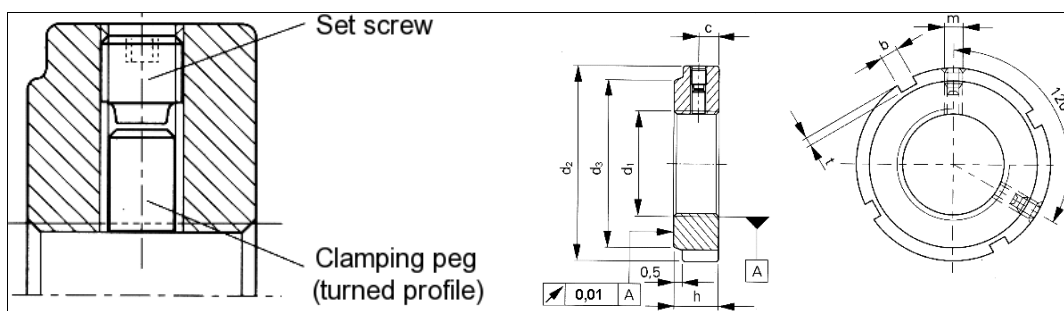

3D-Data available	
Type	turned
Order description	DRS 110x2
Locking system	radial set screw
Axial runout accuracy	0.01 mm
Thread d1 4H	M110x2
d2	145 mm
h	22 mm
d3	133 mm
b	12 mm
t	5 mm
c	11 mm
m	M10
Weight g/part	1200
Material	Steel Rm 800 - 950 N/mm ² Body black finished Bare and lubricated thread and bearing surface
	Type DAS = turned version with axial locking system on request

uniform resource locator: